

User Manual Book

Microwave Oven

Destro Series
MV 3116

Pallazo Series
MV 3133

MODENA

Thank you for your trust in choosing MODENA products for your household needs. With your satisfaction as our priority, we constantly aim to deliver stylishly designed products equipped with state-of-the-art technology to assist you in your daily activities.

This is your guidebook containing everything you need to know about our product. Please reach out to us if you need further assistance or other information via our Customer Care or our official website www.modena.com.

CONTENT	PAGE
Introduction	
- Part 1 : Safety Warning	4
- Part 2 : Name of Parts	7
- Part 3 : Installation	8
- Part 4 : How to Use	8
- Part 5 : Maintenance	20
- Part 6 : Problem & Solution	21
- Part 7 : Precaution	21
- Part 8 : Specification	22

Part 1: Safety Warning

WARNING - To reduce the risk of burns, Electric shock, fire, injury to persons, or exposure to excessive microwave energy:

1. This appliance must be grounded. Connect only to a properly grounded outlet.
2. The unit should digrounding. In the event of a short circuit, grounding reduces the risk of electric shock by providing a release cable for electric current. This unit is equipped with a cord that has a grounding wire with a grounding plug. The plug must be inserted into an outlet that is installed and already diground.
Warning: Incorrect use of the grounding plug can result in a risk of electric shock. Consult with a qualified electrician or service personnel if the grounding instructions are not completely understood, or if there is doubt as to whether the appliance is properly diground. If it is necessary to use an extension cord, use only extension cords with grounding. Ranking marks the extension cord must be equal to or greater than the electrical rating of the appliance.
3. Install or locate this appliance only in accordance with the provided installation instructions. Some products such as whole eggs and sealed containers, for example, closed glass jars, may explode and should not be heated in this oven.
4. Use this appliance only for its intended use as described in this manual. Do not use corrosive chemicals or vapors in this appliance. This type of oven is specifically designed to heat, cook or dry food. It is not designed for industrial or laboratory use.
As with any appliance, close supervision is necessary when used by children.
5. When the unit is operated with a combination mode, use the microwave oven by children must be under the supervision of parents.
6. When the door or door seals are damaged, microwave oven can not be used until repaired first by MODENA technicians.
7. Not recommended except MODENA technician who repair the microwave oven because it is very risky.
8. Liquid and food should not be heated in a state still closed as it may cause an explosion.
9. The microwave oven must have sufficient water flow. Keep a distance of at least 10 cm from the rear, 8 cm from the right and left, 15 cm from the top. Prohibited move the foot of microwave oven, air blocking prohibited.
10. Only suitable tools that can be used for this microwave oven.
11. At the time of heating food in plastic or paper containers, note furnace microwave (microwave oven) because there is the possibility of contact.
12. If any odor / not normal, turn off or disconnect the plug and noticed the door remains closed to withstand fire.
13. Placement of bottles and baby food should be stirred and the temperature should be checked before it is consumed by infants.
14. At the time of cleaning the surface of the door, door hinges, oven space, can only use a mild soap, not rude or detergents with a sponge or soft cloth.
15. Conditions microwave oven that is not clean can cause foaming of the surface which can damage and affect the resistance unit and very risky.
16. Make sure the microwave door is closed when you have finished using it and when not being used.
17. Do not cover or block any openings on the appliance.
18. To clean the outside of the door using a soft non-abrasive soap applied to a soft sponge.
19. Do not use a microwave oven to heat corrosive chemicals (for example, sulfides and chlorides). Steam from the corrosive chemicals may interact with the contact and springs of the safety interlock switch so it can not operate.
20. Keep the waveguide cover clean at all times. Wipe the inside of the oven with a damp soft cloth after each use. Do not let the rest of the oil or fat in the oven space, because they can experience the warm, smoky burn even when using the oven.
21. Liquids, such as water, coffee, or tea are able to be overheated beyond the boiling point without appearing to be boiling due to surface tension of the liquid. Visible bubbling or boiling when the container is removed from the microwave oven is not always present. This could result in very hot liquids suddenly boiling over when a spoon or other utensil is inserted into the liquid. To reduce the risk of injury to persons:
 - a. Do not overheat the liquid.
 - b. Stir the liquid both before and halfway through heating it.
 - c. Do not use straight-sided containers with narrow necks.
 - d. After heating, allow the container to stand in the microwave oven for a short time before moving the container.
 - e. Use extreme care when inserting a spoon or other utensil into the container.

Important Instructions for Use in General

List below, as well as the means - other electronic devices, has rules to be obeyed as safeguards to ensure the functionality of this oven.

- Make sure have plate, roller ring and players plate when using the microwave oven.
- Never use the microwave oven for anything other than food preparation, such as drying clothes, paper or non-food items or for the purpose of sterilization.
- Prohibited operate the microwave oven when empty, it can cause damage to the microwave oven.
- If a fire occurs in the oven, touch the Cancel/Stop button and LEAVE THE DOOR CLOSED. Disconnect the power cord, or shut off power at the fuse or circuit breaker panel.
- Do NOT attempt to dry clothes, newspapers or other materials in the oven. They may catch on fire.
- Do NOT use recycled paper products. Recycled paper towels, napkins and waxed paper can contain metal flecks which may cause arcing or ignite. Paper products containing nylon or nylon filaments should be avoided, as they may ignite.
- Some Styrofoam trays (like those that meat is packaged in) have a thin strip of metal embedded on the bottom. The microwave's metal can burn the floor of the oven or ignite a paper towel.
- Avoid inserting nails, wire, etc. through any holes in the unit during operation. Never insert a wire, nail or any other metal objects through the holes on the cavity or any other holes or gaps, because such objects may cause electric shock and microwave leakage.
- Never use the microwave oven for storage such as paper, cookbooks, and others.
- Prohibited use it to cook food webbed like egg yolks, potatoes, chicken livers and others without first cut.
- Prohibited remove / move the parts of the oven, tamper with or make any adjustments or repairs to the door, control panel or any other part of the oven. Repairs should only be performed by qualified service personnel.
- The microwave oven can only be used in accordance with instructions from the manufacture.
- Prohibited try to fry food in the microwave oven.
- Please note that the microwave oven only heats the liquid in the container, not the container. Therefore, even if the container is not hot to the touch when removing it from the microwave oven, but the food or liquid in it stays hot
- Always do the testing temperature at which food is cooked especially for baby food. It is recommended to not directly consume food / drink directly but let first few minutes so that the heat can be spread evenly.
- Food containing oil and water should be allowed to stand for 30-60 seconds in the microwave oven after is turned off. This is to allow mixing and to prevent scum - scum when a spoon is placed in food or drink or when adding broth into it.
- When preparing or cooking food / drinks, please keep in mind there are several kinds of foods such as pudding, jam, mince where the food is hot. At the time of heating the greasy food and sugar, are prohibited from using plastic containers.
- Cooking tools can be hot because the heat transfers from the food.
- Keep away electronic equipment such as TVs, radios, etc. with the microwave to prevent interference or disruption.
- Tools prohibited used for microwave oven:
 1. Metal pans or dishes with metal handles.
 2. Prohibited wrap the food with plastic.
- Prohibited use of melamine plates, because these materials contain ingredients that can absorb energy from the microwave oven and can cause rupture of the plate and the slow cooking process.

Utensil

1. It is forbidden to cook food directly on the plate. Place the food on the correct tool before inserting them into the microwave oven.
2. Metal containers or dishes with metal trim should not be used. Sparks may occur
3. "Twist-ties" metal cannot be used in a microwave oven.
4. Never use the sealed bottle or bottle with a narrow neck to cook or heat up as it could break.

5. Do not use CONVENTIONAL THERMOMETERS in the microwave oven. Because it can cause sparks.
6. Remove the plastic wrap before cooking or thawing food in the oven.
7. Tools prohibited used for microwave oven.
 - Metal pans or dishes with metal handles.
 - Tools with metal accessories.
 - No food with plastic wrap.
 - No use of melamine plates because these materials contain ingredients that can absorb energy from the microwave furnace (microwave oven) and can cause rupture of the plate and the slow cooking process.

Food

1. Do not use a microwave oven to prepare food cans (with tin). Because canned food can be harmful and dangerous for consumption.
2. The cooking times given in the cookbook are approximate. Several factors may affect the length of cooking time ranging temperature, volume, size and shape of food and equipment used. When you are accustomed to using the oven, you will be familiar and able to adjust these factors.
3. Better cuisine under the conditions ripe than overripe. The food was not too ripe, it can always be returned to the oven to be cooked further. If the food is overcooked, nothing can be done again. Always start with minimum cooking time.
4. The food in small quantities or low humidity levels can burn, dry, if cooked too long.
5. Do not boil an egg in its shell. Pressure can accumulate inside the shell and the egg may explode.
6. Potatoes, apples, egg yolks, whole acorn squash and sausage are some examples of foods with non-porous skin. The skin should be pierced / perforated before cooking to prevent bursting.
7. Popcorn only be processed using a special microwave. Do not use oil unless specified by the manufacturer, or heat for longer than recommended. Never heat the popcorn in paper bag or glass equipment or directly on the glass tray.
8. Do not fry the fat in the microwave. Do not use paper towels to cover food because it can burn.
9. The heated liquid can overflow if not mixed or without stirring first

Part 2: Name of Parts

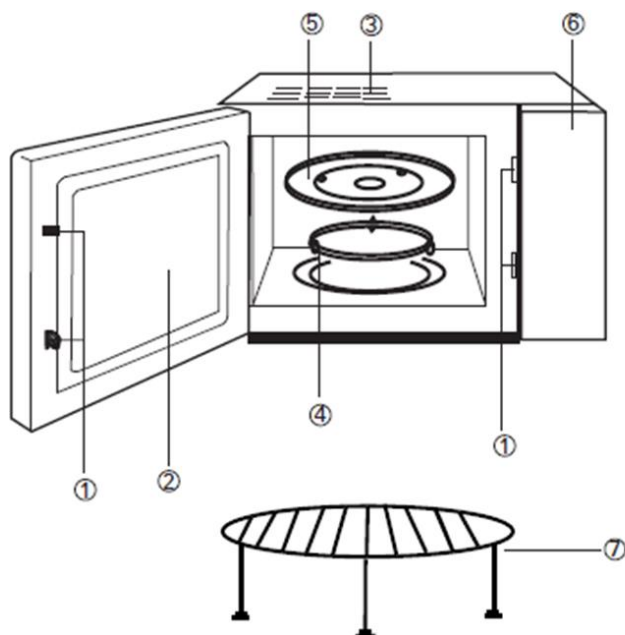

1. Door Safety Lock System
2. Oven Window
3. Oven Air Vent
4. Roller Ring
5. Glass Tray
6. Control Panel
7. Grill Rack

MV 3133

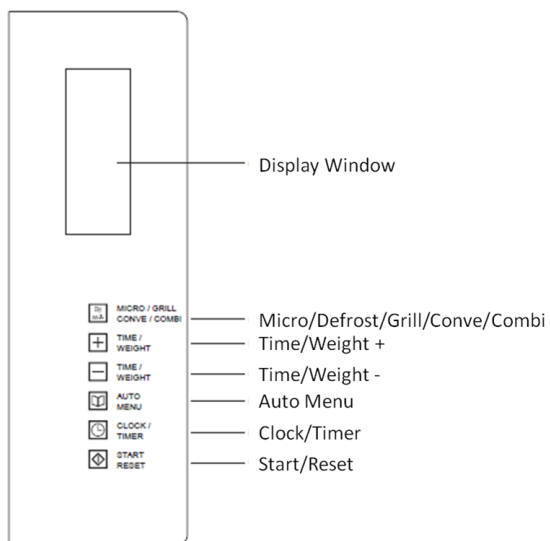

MV 3116

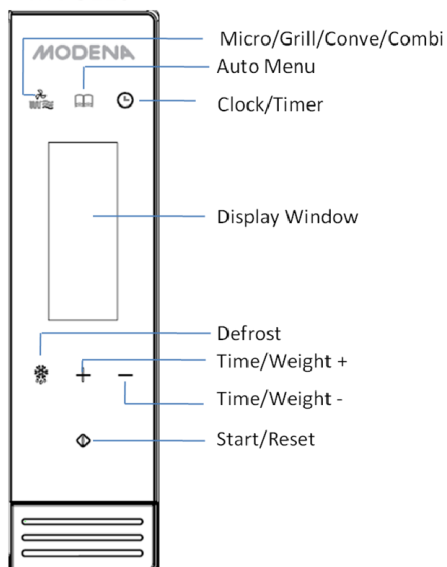

Attention: Please clean microwave oven regularly. Failure to do so may create a fire hazard and void the warranty

Part 3: Installation

1. Make sure all the packing materials are removed from the inside of the door.
2. Inspect the oven after unpacking for any visual damage such as :
 - Misaligned Door
 - Damaged Door
 - Dents of Holes in Door Window and Screen
 - Dents in CavityIf any of the above is visible, DO NOT use the oven.
3. This microwave oven weighs around 16 kg and must be placed on a horizontal surface strong enough to support this weight.
4. The oven must be placed away from high temperature and steam.
5. DO NOT place anything on top of the oven.
6. On the use of freestanding, leave a space of at least 10 cm from the rear, 8 cm from both sides of the wall and 15 cm from the top to ensure proper ventilation.
7. On the use of a built-in (planted), adjust the distance by following the installation of an appropriate frame.
8. DO NOT remove the turn-table drive shaft.
9. As with any appliance, close supervision is necessary when used by children.

WARNING:

1. The plug socket should be within easy reach of the power cord.
2. This oven requires 1.5 KVA for its input. Consultation with service engineer is suggested when installing the oven

CAUTION: This oven is protected internally by a 250V, 10 Amp Fuse.

NOTE:

The wires in this mains lead are coloured in accordance with the following code:

Green-and-yellow : Earth
Blue : Neutral
Brown : Live

As the colours of the wires in the mains leads of the appliance may not correspond with the coloured markings identifying the terminals in your plug, proceed as follows:

- The wire which is coloured green-and-yellow must be connected to the terminal in the plug which is marked by the letter E or the earth symbol indicated by green and yellow colour.
- The wire which is coloured blue must be connected to the terminal which is marked by the letter N or by the black colour.
- The wire which is coloured brown must be connected to the terminal which is marked by the letter L or the red colour.

Part 4: How to Use

4.A. Single Button Heating

Only with a single press of a button, you can start simple cooking, it is very convenient and quick to heat a glass of water, etc.

Example: to heat a glass of milk

- Put a glass of milk onto the glass turntable and close the door.
- Press the button —Start/Reset, the microwave oven will work on 100% power for 1 minute.
- You will hear 5 beeps when cooking is completed

4.B. Microwave Heating

This function has two options:

1. Quick microwave heating (100% power)

Example: to heat food on 100% power for 5 minutes

- set time to —5:00ll
- Press —Startll

2. Manual-operation microwave heating

Example: to heat food on 70% power for 10 minutes

- Press —Power/Grillll button, select 70% power
- Set time to —10:00ll
- Press —Startll

There are 5 power levels and the longest microwave cooking time is 60 minutes.

Touching Times	Microwave Power	Display
1	100%	P100
2	70%	P70
3	50%	P50
4	30%	P30
5	10%	P10

4.C. Auto weight defrost

Select the weight of the frozen food; it will automatically help you to adjust the power level and time.

Example: Defrost 0.5 kg frozen meat

1. For MV 3116: Press defrosts function —Auto defrostsll until —DEFll display. For MV 3133: Press "Micro/Defrost/Grill/Conve" to select "DEF".
2. Input the weight by pressing the button "Time/Weight+" and the button "Time/Weight-"
3. Press —Start/Resetll

Attention: The weight of frozen food must be less than 2kg

4.D. Auto-Menu

You only need to select the food type and weight; it will help you to automatically adjust the power and time.

Example: Auto cooking a 0.4kg fish

1. Choosing Menu: PressllAuto Menull button untilllA-5ll displayed.
2. Determine the weight by pressing the button "Time/Weight+" and the button "Time/Weight -ll, until "0.4" displayed.
3. Press =Start/Resetll

Menu Weight Series No.	Reheat (A-1)	Potato (A-2)	Meat (A-3)	Pizza (A-4)	Fish (A-5)	Chicken (A-6)
1	0.10	0.20	0.10	0.10	0.10	0.20
2	0.15	0.30	0.20	0.20	0.20	0.40
3	0.20	0.40	0.30	0.25	0.30	0.60
4	0.25	0.50	0.40	0.30	0.40	0.80
5	0.30	0.60	0.50	0.35	0.50	1.00
6	0.35	0.70	0.60	0.40	0.60	1.20
7	0.40	0.90	0.80	0.45	0.70	1.40
8	0.45	1.10	1.00	0.50	0.80	1.60
9	0.50	1.30	1.30	0.55	0.90	1.80
10	0.60	1.50	1.50	0.60	1.00	2.00

4.E. Grill

You may press —Micro/Grill/Combi/Covell to select such functions: (the longest cooking time is 60 minutes).

Example: Cooking food with grill for 20 minutes

1. Press —Micro/Grill/Combi/Covell until LED displayed —G-1||
2. Set cooking time —20:00||
3. Press —Start||

When grilling, the food isn't heated by microwave; heat is radiated from the metal heater at the top of the oven. When grill is working, the cooking time has 2 stages, after the 1st half of the cooking, the program will automatically pause and sound 2 beeps, indicating you to open the oven and turn food over, close the door after turn the food over, press —Start/Reset|| button, the cooking will continue for the 2nd half. If you do not want to turn the food over, the oven will re-start after 1 min pause.

4.F. Combination Cooking

This appliance offers you a choice of two methods of combination cooking.

Option 1: Convection +Microwave (230° C Convection + 40% microwave), display —C-1|| this is ideal for roasting and baking etc.

Option 2: Grill and Convection (50% grill + 230 ° C convection), display —C-2|| this is for fast crisping etc.

Option 3: Grill and Microwave (45% grill + 55% microwave), display —C-3|| This is for fast grilling etc.

Example: cooking food using option 3 for 30 minutes

1. Press —Micro/Grill/Combi/Convell button to select —C-3||
2. Set cooking time for 30 minutes
3. Press —Start/Reset||

4.G. Convection Cooking

This oven can be used as a convection oven and be programmed to reach a desired temperature for pre-heating. The temperature setting will default to 230° C. Press —Micro/Grill/Combi/Convell button to set the different temperature.

I. Pre-heat functions

Example: To set the oven to pre-heat to 200° C.

1. Press the — Micro/Grill/Combie/Convell button to choose 200 ° C. temperature
2. Press —Start/Reset||
3. The pre-heating is completed when the oven setting temperature is readed. The longest pre-heating time will be 30 minutes.

II. Convection function

Example: Convection cooking, to set the convection cooking minutes at 200 ° C.

1. Press the —Micro/Grill/Combie/Convell button to choose convection cooking and choose 200 ° C temperatures.
2. Set cooking time for 20 minutes.

3. Press —Start/Resetll.

4.H. Clock

The oven has 24-hour digital clock,

To input the time, for example to 16:30:

1. Press "Clock/Timer", the display will flash, adjust the hour with buttons "Time/Weight+" and "Time/Weight-".
2. Press "Clock/Timer" again, adjust the minute with buttons "Time/Weight+" and "Time/Weight-".
3. Press "Clock/Timer" again and the clock will be set.
4. If you want to change the time, repeat above procedure

4.I. Timer

This allows you to set the microwave oven start and finish cooking at pre-set time. The clock must be set before you use this feature.

Example: The current time is 16:30 and you want to start cooking at 18:15 on 70% power for 10 minutes:

1. Press —Clock/Timerll and set time to 18:15 (same procedure as setting clock).
2. Press —Micro/Grill/Combi/Convell to set 70% power.
3. Input cooking time 10 minutes by rotating the knob —the settingll.
4. Press —Start/Resetll.

If you do not set the power and cooking time and directly press the —Start/Resetll button, the microwave will work only as a clock. There will be 10 beeps at 18:15, but no other function will run.

4.J. Child-safety-lock

To activate the child safety lock, press —auto Menull and _Clock/Timerll button at the same time for 2 seconds.

Press _auto Menull and —Clock/Timerll button, at the same time for 2 seconds again, it will unlock this function.

4.K. Start/Reset

1. In the course of operation, press —Start/Resetll button will stop operation.
2. If any program was set before pressing start, press this button will cancel the entire set program.

4.L. COOKING GUIDE

THE PRINCIPLES OF MICROWAVE COOKING

Microwaves are a form of high frequency radio waves similar to those used by a radio including AM, FM and CB.

Electricity is converted into microwave energy by the magnetron tube. From the magnetron tube, microwave energy is transmitted to the oven where it is reflected, transmitted and absorbed by the food.

Reflection Microwaves are reflected by metal just as a ball is bounced off of a wall. For this reason, metal utensils are not suitable for use in the microwave. A combination of stationary interior walls and a rotating metal turntable or stirrer fan helps assure that the microwaves are well distributed within the oven cavity to produce even cooking.

Transmission

Microwaves pass through some materials such as paper, glass and plastic much like sunlight shining through a window. Because these substances do not absorb or reflect the microwave energy, they are ideal materials for microwave oven cooking containers.

Absorption

During cooking, microwaves will be absorbed by food. They penetrate to a depth of about 3/4 to 1 1/2 inches. Microwave energy activates the molecules in the food (especially water, fat and sugar), and heat is produced. If you vigorously rub your hands together, you will feel heat produced by friction. The internal cooking of larger foods is done by conduction as the heat which is produced by friction is conducted to the middle of the food. Foods also continue to cook by conduction during standing time.

FOOD CHARACTERISTICS

Quantity: The amount of food placed in a microwave oven has a direct effect on the cooking time. Small amounts of food or liquid require less cooking time than larger amounts of the same substance. As quantity increases, concentration decreases.

Size: Small pieces cook faster than large ones. To speed up the cooking process, cut pieces smaller than two inches (5 cm), so microwaves can penetrate to the middle from all sides. Pieces which are similar in size and shape cook more evenly.

Shape: Many foods are uneven, like a chicken, ribs or broccoli. The thin parts will cook faster than the thick parts, while uniformly thick foods cook evenly. To compensate for irregular shapes, place thin pieces toward the center of the dish and thicker pieces toward the edge of the dish.

Starting Temperature: Frozen or refrigerated foods take longer to cook than foods at room temperature.

Bone and Fat: Because bones conduct heat, the side of the meat the bone is on will cook first, while boneless cuts cook slower but more evenly. Fat attracts microwaves. The middle of these foods are cooked by heat conduction.

Moisture Content: Microwaves are attracted by moisture. Naturally moist foods absorb microwaves better than dry ones. Add a minimum of liquid to moist foods, as excess water slows cooking.

Density: The density of food determines how easily the microwaves can penetrate and how quickly it will cook. Porous foods, like chopped beef or mashed potatoes, microwave faster than dense ones like steak or whole potatoes.

Piercing: Steam builds up pressure in foods which are tightly covered by a skin or membrane. Pierce potatoes, egg yolks and chicken livers to prevent bursting.

MICROWAVE TECHNIQUES

Stirring: Stir foods from outside to center of dish once or twice during cooking to equalize heat and speed microwaving. Foods will not burn or stick, so there's no need to stir constantly as you do in conventional cooking.

Arrangement: Arrange foods with thin or delicate end, like drumsticks or asparagus spears, with the thick or tougher portions to the outside of the dish. The parts which need more cooking will receive more energy, so food will microwave evenly.

Spacing: Individual foods, such as baked potatoes and cupcakes will cook more evenly if placed in the oven an equal distance apart. When possible, arrange foods in a circular pattern. Meaning that when placing foods in a baking dish, arrange it in a round shape instead lining them up next to each other. Food should not be stacked on top of each other.

Rearrangement: Rearrange overlapping areas, like the tails of long fish fillets, from top to bottom, and closely packed pieces, like meatballs, from the outside to the center of the dish.

Standing Time: Standing time is currently undergoing a process where the cuisine greater heat dissipation inside immediately after the cooking process is finished, for example meat temperature will rise about 5° – 8° C (about 9 ° -15 ° F) during the standing time. This period is very important in cooking with a microwave. Microwaves cause outer layer of thermal energy food, as a result of the normal conduction, the food is still undergoing a process of heating a few minutes after being removed from the oven, let dishes such as grilled meat, thin foods, cakes and vegetables in bulk, completion of this stage in order to be a central part fully ripe, without too mature, dry or too crisp on the outside.

Covering: Covering speeds cooking time, retains moisture, tenderizes, insures even cooking and prevents spattering.

Casserole lids or plastic wrap are used for a tighter seal. Vent plastic by turning back one edge at the side of dish to form a narrow slot where excess steam can escape. Various degrees of moisture retention are also obtained by using microwaveable cover.

Browning

Caramelize and give a "browned" appearance. Browning agents do not affect the quality of microwaved foods, but can add color and flavor. For meats and poultry, use sauce diluted with water or melted butter, soy, Worcestershire, barbecue or steak sauce, a sprinkling of paprika or dry gravy mix; jelly glaze or crumb coating.

Frosting and topping finish cakes and breads. Top casseroles at the end of microwaving with grated cheese or crumbs.

Some Foods Do Not Microwave Well

Eggs in Shells and hard boiled eggs can burst.

Pancakes do not crust, but they reheat well. Fully-prepared, frozen pancakes are available for microwaving.

Deep Fat Frying can cause burns.

Bottles with narrow necks may shatter if heated.

Popcorns only in special microwave poppers. Do not use oil unless specified by the manufacturer, or heat longer than recommended. Never pop popcorn in paper bags or glass utensils or directly on the glass tray.

HOT SNACKS AND APPETIZERS

Hot hors d'oeuvres and appetizers can be prepared very quickly in the oven by the hostess, or individual servings may be prepared by guests. Many appetizers may be cooked on the serving platter, provided the platter does not have metal trim. A time saving tip -prepares these foods ahead of time, refrigerate or freeze, and reheat in the oven at serving time. A plate of appetizers will take only seconds to prepare or reheat.

Cheese melts very rapidly and will toughen if overcooked, so watch foods combined with cheese closely so that overcooking will not occur. As soon as cheese starts to bubble, cooking is completed. Appetizers that have a crisp pastry exterior are best prepared in a conventional oven. To prepare appetizers wrapped in bacon, it will be necessary to precook the bacon and then wrap around the foods.

Oysters wrapped in bacon are easier to prepare in the broiler of your conventional range.

Seafood mixtures can be prepared in serving shells as microwave energy will pass through the seafood shells without heating. Aluminum foil should not be used for shells.

If spreads are placed on crackers, care should be taken not to overcook as moisture from the food will cause crackers to become soggy. Crackers used for spreads should be very dry and crisp. This helps avoid sogginess. Heat only until spread is at serving temperature.

The time required to heat all appetizers will depend on the amount of food, and the number and the type of dish selected. Remember the food will become very hot even if the dish is cool. Cheese mixtures retain heat longer when heated with microwave energy.

MEATS

Guide for Cooking Meats

Roasts, chops, hamburgers and small cuts of tender meat cook beautifully in the microwave oven. Most roasts can be cooked rare, medium rare or even well done in less than one hour. Less tender cuts of meat such as pot roast can be simmered fork tender in a sauce or gravy. Tough cuts that require slow cooking will do better in the conventional range or oven. A large piece of meat, especially if the shape is uneven, should be turned over occasionally for uniform roasting.

Meat	Power Level	Cooking (per lb)	Time	Standing Time	Notes
Beef Roast					Turn over half the time. after
Rare	80	6 – 8 minute	5 – 7 minute		
Medium	80	8 – 10 minute	10 – 15 minute		
Well	80	10 – 12 minute	10 – 15 minute		
Pork Roast					Cover with microwaveable cover. Turn over after half the time.
Bone-in	80	12 - 15 minute	10 minute		
Boneless	80	16 - 18 minute	10 - 15 minute		
Lamb Roast					Turn over half the time. after
Bone-in Medium	80	7 - 9 minute	10 - 12 minute		
Bone-in Well	80	9 1/2 -11 1/2 men.	10 - 15 minute		
Boneless Medium	80	9 - 11 minute	10 - 12 minute		
Boneless Well	80	11 - 13 1/2 minute	10 - 15 minute		
Beef Patties (3 1/2 oz) each					Turn it over and rearrange after in the half time of the process.
2 patties	100	2 1/2 - 3 minute	5 - 7 minute		
4 patties	100	3 1/2 minute	4 1/2	5 - 7 minute	
Meat Loaf					Cover with microwaveable cover.
(2lbs)	100	15 - 17 minute t	10 - 12 minute		

Bacon				Cover with microwaveable cover.
Slices (4 strips) (1 slice; weight: 1 oz, length: 11 in.)	100	4 - 5 minute	—	
Ham				Cover with microwaveable cover.
Slices (1 in. thick) 4 slices	7 1/2 - 8 1/2 min.	5 - 7 minute		

POULTRY

Guide for Cooking Poultry

Chicken is one of the most popular foods and microwaving chicken is one of the best uses of your microwave oven. Chicken stays juicy and tender in the microwave oven. However, juiciness prevents browning because chicken crisps and browns only when the skin dries out enough to change color.

Standing time is important, because it allows the interior to finish cooking without toughening the delicate breast meat.

Food	Power Level	Cooking Time (per lb)	Standing Time	Notes
Roast				
Chicken wholer	100	6 – 8 minute	10 – 15 minute	Place breast side up on roasting rack. Let stand, covered, before serving.
Chicken cut up	100	8 – 7 minute	7 – 10 minute	
Turkey	80	6 1/2 – 8 minute	7 – 10 minute	
Turkey Breast	50	10 – 11 minute	5 – 7 minute	Rearrange once during Rearrange once during with microwaveable cover.

SEAFOOD

Guide for Cooking Seafood

Microwaving is one of the easiest and most efficient ways of preparing fish and seafood, which stay delicate and tender with quick, moist cooking. Overcooking dries out and toughens seafood, so you should check it after the minimum time. If thick pieces like fish steaks or lobster tails are done on the outside, but still slightly translucent in the middle, let them stand for a few minutes; internal heat will complete the cooking.

Food	Power Level	Cooking Time	Standing Time	Notes
Whole Fish (1 lb to 1 ½ lbs)	100	6 – 7 menit	5 menit	Turn over after half the time.
Fish Fillet (1 lb)	100	5 – 6 menit	4 – 5 menit	
Fish Steak 1 inch thick (1 lb)	100	4 – 5 menit	5 – 6 menit	Turn over after half the time. Cover with microwaveable cover.
Shrimp (1 lb)	100	3 – 4 menit	5 menit	Rearrange once during cooking. (1 lb) Cover with microwaveable cover.
Sea Scallops (1 lb)	80	6 – 7 menit	5 menit	

EGGS & CHEESE

Guide for Cooking Eggs & Cheese

CHEESE

Cheese melts quickly and smoothly. When serving cheese as an appetizer, flavor is at peak when served at room temperature. Use a low power level for melting. Cheese melts best when shredded and heated with milk or other liquids. Stir cheese mixtures several times for even heating.

EGGS

Eggs cook differently by microwave. The high fat content of egg yolks absorbs energy, so yolks cook faster than whites. It's easy to poach eggs in a microwave oven, but if you want soft yolks, remove eggs from the oven before whites are completely cooked. A brief standing time allows whites to set without overcooking yolks. Check eggs for completion of cooking early, they toughen when overcooked.

When eggs and yolks are mixed together for omelets, scrambled eggs or custards, they cook more evenly and need less stirring than during conventional cooking methods.

Do not try to cook eggs in the shell. Steam can build up inside the shells, causing them to burst.

Scrambled Eggs

Eggs	Butter	Milk or Water	Power Level 100	Procedure
2	1 Tbsp	2 Tbsp	1 – 2 minute	Place butter in small casserole and melt. Add eggs and milk, scrambling with fork. Cook as directed in chart, breaking up and stirring eggs twice. Let stand, covered, before serving.
4	1 Tbsp	2 Tbsp	2 – 3 minute	
6	2 Tbsp	4 Tbsp	3 – 4 minute	

Poached Eggs

Eggs	Water	Cook with Power Level 100	Cook Eggs on Power Level 80	Standing Time	Prosedur
1	1 ½ cups	4 – 6 minute	1 minute	2 minute	Place water into medium casserole. Cook at high until boiling. Break eggs, one at a time, into separate dish, pierce yolk once with wooden pick and slip egg carefully into hot water, cook as directed in chart.
2	1 ½ cups	4 – 6 minute	1 1/2 – 2 minute	2 minute	
4	2 cups	6 – 7 minute	2 1/2 – 3 minute	2 minute	

VEGETABLES

Guide for Cooking Fresh Vegetables

Nutrition research indicates that many microwaves vegetables and fruits lose less water soluble vitamin C than when cooked conventionally. This is due to shorter cooking time and to the fact that less cooking water is needed when microwaving fruits and vegetables. Best of all, vegetables keep their fresh color, texture and flavor. Vegetables should be covered with microwaveable cover. Vegetables cooked in their skins, such as potatoes, are already so tightly covered that they should be pricked with a fork before cooking in order to release excess steam. To assure even cooking, vegetables should be cut in uniform pieces and stirred during the cooking time. Always add salt to water before adding vegetables. Reduce time a minute or two for crisp-tender texture. Increase time for very soft texture. Remember to allow standing time of two to five minutes after

cooking because, as most foods do, vegetables will continue to cook after they are removed from the microwave oven.

Food	Amount of Water	Cook on Power 100	Standing Time	Notes
				Medium Casserole. Re-arrange once.
Spears (1 lb)	¼ cup	5 – 6 minute	2 minute	
Cuts (1 lb) ½ cup		5 – 6 minute	2 minute	
.Beans				
Fresh green (1/2 lb)	¼ cup	4 – 5 minute	2 minute	Stir twice.
Frozen green (1/2 lb)	2 Tbsp	5 ½ - 6 ½ minute	2 minute	Stir twice.
Green Peas (2 cups)	¼ cup	4 – 5 minute	2 minute	Small casserole. Stir twice.
Broccoli (2 cups)	¼ cup	4 – 5 minute	2 minute	Medium casserole. Rearrange once during cooking.
Brussels Sprout (1 lb)	¼ cup	6 – 7 ½ minute	2 – 3 minute	Medium casserole. Stir once.
Cabbage (1 lb)	¼ cup	5 – 6 minute	2 – 5 minute	Rearrange once during cooking.
Cauliflower pieces (1 head)	¼ cup	6 – 7 minute	2 – 5 minute	Cover with microwaveable cover. Stir once.
Mushroom slices (1/2 lb)	2 Tbsp	3 – 4 minute	2 – 3 minute	Small casserole. Stir once.

SOUPS

Guide for Cooking Soups

Satisfy appetites with savory soups prepared in your microwave oven. Adapt your favorites by using similar cooking times and techniques.

Food	Power Level	Cook on Power 100	Standing Time	Notes
Canned Condensed				
Cream style, Bean, Pea or Mushroom (10 ½ - 11 1/2 oz)				Stir halfway through. Cooking time. Cover.
With Water	100	4 ½ - 5 ½ menit	2 – 3 minute	
With Milk	80	5 ½ - 6 ½ menit	2 – 3 minute	
Dry Soup Mix	100 then	5 ½ - 6 ½ menit	2 – 3 minute	Add water. Cover with lid. Stir twice.
1 envelope (10 1/2 oz)	50	3 – 4 menit		
Broth (10 ½ oz)	100	4 – 5 menit	2 – 3 minute	Stir twice. Cover

SAUCES

Guide for Cooking Sauces

Sauces boil over rapidly, especially those that contain milk. As soon as the door is opened, cooking stops. If ingredients are not taken directly from the refrigerator, cooking time will be less than given in the recipe. Stir sauce quickly, about every 30 seconds to eliminate lumps. Be sure to use a container twice the size of the amount of liquid to prevent boiling over.

A wooden spoon may be left in the dish while sauce is cooking for easy stirring. If sauce is stirred slowly, cooking time may require about 15 seconds longer. If desired, a 1 quart glass measure may be used to prepare some sauces.

White Sauce

Amount		Butter	Flour	Milk	Cook Butter	Cook Sauce	Notes
1 Cup	Thin	1 tbs	1 Tbs	1 cup	30 seconds	2 ½ - 3 ½ minute	Cook on Full power as directed or until thickened, stirring once. Let stand, covered, before serving.
	Med	2 Tbs	2 Tbs	1 cup	1 minute	2 ½ - 3 ½ minute	
	thick	3 Tbs	3 tbs	1 cup	1 minute	3 – 4 minute	

Brown Gravy

Amount		Fat from Drippings	Flour	Liquid or Drippings	Cook on Power Level 100	Notes
1 Cup	Thin	1 tbs	1 Tbs	1 cup	2 ½ - 3 ½ minute	Cook on Full power as directed Or until Thickened, stirring once. Let stand, covered, before serving.
	Med	1 Tbs	1 Tbs	1 cup	3 – 4 minute	
	thick	1 Tbs	1 tbs	1 cup	3 – 4 minute	

CASSEROLES

Casseroles may require occasional stirring to distribute heat. They cook more evenly when made with ingredients of similar size and shape. Because of their shorter cooking time, casseroles cooked in the microwave oven generally need less liquid. Casseroles with cream and cheese sauces, or meats which need slower cooking to tenderize, cook best on power level 40. When cooking a favorite casserole, make two and freeze the second for future use. Line a casserole or baking dish with microwaveable cover. Transfer the cooked food to the lined container and freeze. As soon as the food is frozen in the shape of the dish, remove it and wrap with freezer paper. Later it can be unwrapped and returned to the container for defrosting and heating

Dry Casserole Mixtures

Many prepared box type casseroles are available on the grocery shelves. Many have frozen dried foods or evaporated foods included. Cooking periods are so short there may not be time for the foods to absorb the moisture sufficiently and reconstitute the foods. To prepare this type, boil the amount of water recommended

on the package. Add the noodles (when included), cover and cook for approximately 10 minutes. Allow noodles to stand covered for an additional 10 minutes, rinse with warm water and drain. Then follow package directions for preparing the mix. Reheat 4 to 6 minutes before serving.

SANDWICHES, INCLUDING HAMBURGERS AND HOT DOGS

Guide for Heating Sandwiches

Sandwiches heat very quickly because, being porous, they have a low density. Since the filling is usually denser than the bread or rolls, the filling determines the heating time. Surprisingly, the filling will always be hotter than the bread feels. Care must be taken not to overcook as the bread will become tough. Use several thin slices of meat. Thin slices heat more quickly and are better than one thick slice. The slow heating thick slice often causes the bread to overcook before the meat is hot. Sandwiches may be placed on a paper plate. Remove wrapping immediately after warming. Already- baked frozen breads and rolls may be used for sandwiches. The filling, however, should be thawed first. Toasted bread is fine for sandwiches and provides a firm base. The toast is warmed only; no further browning occurs.

Food	Amount	Cook on Power	Special Notes
Sandwich	1	1 min	Place on microwaveable plate.
	2	1 ½-2min	
	4	3-4 min	
Hamburger (4 Oz)	4	1 min 3-4 min	Cover with microwaveable cover
Hot Dogs	4	1 ½-2min	Cover with microwaveable cover
Sloppy Joes	4	4 min	Place on microwaveable plate.

PASTA & GRAINS

Guide for Cooking Pasta and Grains

Raw long grain rice takes time to rehydrate. Microwaving time is a little shorter than conventional, but the greatest advantage is the ease with which you can prepare fluffy rice without sticking or burning. Cooked rice and pasta reheat easily in the microwave oven without loss of flavor or texture. No extra water is needed to prevent sticking or drying, so there's no danger of overcooking rice and pasta or thinning sauces.

Food	Hot Water	Salt	Oil Butter	or	Power Level	Cooking Time	Standing Time
Pasta (8 oz)							
Egg Noodles	4 cups	1 tsp.	1 Tbsp.		100	6 ½ minute - 7 ½	2 – 5 minute
Macaroni	4 cups	1 tsp.	1 Tbsp.		100	8 – 10 minute	2 – 5 minute
Spaghetti	4 cups	1 tsp.	1 Tbsp.		100	8 – 10 minute	2 – 5 minute
Lasagna Noodle	4 cups	1 tsp.	1 Tbsp.		100	12 – 14 minute	2 – 5 minute
Rice, Long Grain							
Rice	2 cups	1 tsp.	1 tsp.		100	5 -6 minute	5 – 7 minute
					then 80	9 ½ - 12 minute	
Red Rice	2 cups	½ tsp.	1 tsp.		100	5 – 6 minute	5 – 7 minute
					then 80	22 – 27 minute	

CEREALS

Microwaveable hot cereals can be cooked directly in the cereal bowl and make cleaning up easy.

CONVENIENCE FOODS

Frozen Foods

A large variety of frozen foods, special dishes and dinners are available and the selections continue to increase. The market is changing rapidly, therefore it is impossible to list the foods and types available and recommend cooking procedures. In this book we can only give general directions to assist you.

T.V. Dinners

To prepare a T.V. dinner, follow the maker's instructions for use with microwave ovens. Cooking a T.V. dinner will require approximately five to seven minutes for the food to thaw and heat to serving temperature (depending on the types of food).

Allow plastic wrap to remain over the dish for two minutes to allow heat to equalize. Dinners that contain mashed potatoes have presented a bit of a problem due to the large compact mass of this particular food. You may want to remove about half the mashed potatoes after defrosting is started, then spread the remaining potatoes over the individual section of the tray. Heat the removed mashed potatoes in an individual dish. For foods that should be crisp when cooking is completed, remove the plastic wrap and use the broiler of a conventional range to crisp the food.

Individual Frozen Foods

These may be commercially prepared or frozen at home. Place the container of frozen food in the oven and heat only until the food starts to defrost and can be removed easily. Empty contents into a casserole or serving dish and continue to defrost and heat. Do not heat foods in deep foil containers. To crisp and brown special toppings, use the broiler of a conventional range. If allowed to heat to serving temperature in a plastic container, the container will warp or melt from the high heat of food.

Frozen Foods in Cooking Pouches or Boilable Bags

To prepare these foods, slit the plastic bag. An X-type cut will help remove the food at the end of cooking time. Place the cut side down on a serving dish (with no metal trim). Heat foods other than vegetables for about three minutes. Frozen vegetables require about eight to nine and a half minutes of cooking time. Allow the pouch bag to remain over the food for about two minutes to allow time for the heat to equalize. Foods prepared in cheese or white sauce should be removed from the pouch and placed in a glass casserole dish and stirred to prevent overcooking of the sauce around the edges of the dish.

Complete Meals from Table Leftovers

Complete meals from leftovers can be prepared in advance. Foods can be frozen and ready for quick heating in the oven at any time. Choose foods suitable for freezing and put serving portions on paper, glass or china (no metal trim) plates. Wrap with recommended freezer paper and freeze quickly. When portioning the servings of food on the plate, use approximately the same amount of each kind of food for more even heating. Mashed potatoes will heat quicker if spread slightly and hollowed, with a pat of butter in the center. To prevent small pieces of vegetables, corn, peas, etc., from dehydrating during heating, mound well near the center of the plate.

DESSERTS

There's always time to make dessert with a microwave oven. Fruit desserts have a remarkably fresh flavor and texture. Microwave cakes are higher and more tender than conventionally baked; since cakes are usually frosted, browning is unimportant. Microwave pie crusts are exceptionally tender and flaky, while delicate custards and puddings are easy to prepare.

Type of Food	Power Level	Cooking Time	Standing Time	Notes
Cake, Round(Mixed 9 inch)	100 80	3 ½ - 5 minute 4 ½ - 6 minute	2 – 5 minute	Pour into greased and wax paper lined cake dishes.
Ring or Angel Food Cake	80	5 ½ - 6 ½ minute	2 – 5 minute	Cover with wax paper.
Muffin (6 Muffins)	50	4 ½ - 6 ½ minute	2 – 5 minute	Rearrange once.
Custard (6 servings)	50	10 – 12 minute	2 – 5 minute	Rearrange once.

Baking

- Bar cookies work best. Greasing or lining of the microwaveable baking dish is optional.
- If insufficient browning disturbs you, frost, glaze or add food coloring to white or yellow batters.
- A microwaveable cookie sheet can be made by covering cardboard with waxed paper.
- Because your cakes will rise higher in microwave cooking, never fill microwaveable cake pans more than half full.
- Reduce baking powder and soda by approximately one-fourth when converting a conventional recipe.
- Fill paper-lined muffin cups to only half full which allows for muffins to rise more than normal.
- You can prepare your own "brown 'n serve" breads and rolls by baking them ahead of time in the microwave oven. Then, place them in a conventional oven to brown prior to serving.
- Breads and rolls should be reheated to the point where they are warm to the touch. Overheating or overcooking makes bread tough and rubbery.
- When making yeast bread in a microwave oven, choose a recipe with cornmeal, whole wheat flour, or rye flour to achieve a richer color.

OUNCES (oz)	GRAMS (g)	OUNCES (oz)	GRAMS (g)
1	28	9	255
2	67	10	284
3	85	11	312
4	113	12	340
5	142	13	369
6	170	14	397
7	198	15	425
8	227	16	454

POUNDS (lbs)	GRAMS (g)
¼	114
½	227
¾	341
1	454
2	907
3	1361
4	1814
5	2268
6	2722
7	3175
8	3629
9	4082
10	4536
11	4990

Fluid Measurements

1 Cup =	4 fluid ounces =	120 ml
1 Pint =	16 fluid ounces =	480 ml
1 Quart =	32 fluid ounces =	960 ml
1 Gallon =	128 fluid ounces =	3840 ml

Part 5: Maintenance

- Before cleaning, turn off the microwave oven and remove the plug from its socket.
- Keep clean the microwave oven. If food falls or spilled liquid attached to the furnace wall of the microwave (microwave oven), wipe with a damp cloth. It is not recommended to use detergents and abrasive.
- The outer surface of the microwave oven should be cleaned with a damp cloth. To prevent damage to the parts inside the microwave oven, water should not be entered into the ventilation openings.
- Do not allow the control panel to be wet. Clean with a soft cloth and wet. Do not use detergent, abrasive cleaners or spray for the control panel.
- If steam buried inside or outside around the door, wipe with a soft cloth. This may occur when the

microwave oven is operated under conditions of high humidity and do not cause errors / malfunctions.

- Sometimes it is important to move the Spinning plate to be cleaned. Clean with warm water and foamy or dishwasher.
- Roller ring and the player base cabinet microwave oven must be cleaned regularly to prevent excessive noise. Clean the bottom surface of the stove microwave (microwave oven) with mild detergent, water, glass cleaner and dry. Player rings should be washed with foamy water or dishwasher. Steam when cooking collected during repeated use but does not affect the surface of the wheel base or player ring. At the time of transfer of the player base cabinet ring for cleaning, be sure to put them back in the correct position.
- Eliminate odors in the microwave oven by mixing one cup of water with lemon juice and peel of the fruit in a bowl microwave oven. Operate the microwave oven for 5 minutes, wipe and dry with a soft cloth.
- If you need to change the lamp microwave oven, consult an electrician first

Part 6: Problem and Solution

Consult the following troubleshooting before contacting our Service Center regarding your microwave oven:

Normal	
Microwave oven interfering TV reception	Radio and TV reception may be interfered when microwave oven operating. It is similar to the interference of small electrical appliances like mixer, vacuum cleaner, and electric fan. It is normal.
Dim oven light	In low power microwave cooking, oven light may become dim. It is normal.
Steam accumulating on door, hot air out of vents	In cooking, steam may come out of food. Most will get out from vents. But some may cumulate and cool place like oven door. It is normal.
Oven started accidentally with no food in.	It is forbidden to run the unit without any food inside. It is very dangerous.

Problem	Possible cause	Remedy
Oven cannot be started	Power cord not plugged in tightly	Unplug. Then plug again after 10 second.
	Fuse blowing or circuit breaker works.	Replace fuse or reset circuit breaker (repaid by professional personal of Modena).
	Problem with outlet	Test outlet with other electrical appliances.
Oven does not heat	Door not closed well	Close door well
Glass turntable makes noise when microwave oven operates	Dirty roll rest and oven bottom	Refer to "maintenance of microwave" to clean dirty part.

Part 7: Precaution

Basic Preventive Measures Should Always Look For When You Using Microwave Oven are:

1. Read the instructions carefully before operating.
2. Ensure that the voltage indicated on the back of the unit in accordance with the voltage in your home before you connect the device to a power source.
3. Remove the plug from the socket before you insert and remove accessories and before you clean the microwave oven) . Always remove the plug from the socket when you have finished using it or if it is not being used.
4. Do not operate the microwave oven if the power cord or plug is damaged, not working properly, the microwave oven is dropped or damaged for any reason. Bring to MODENA Service Center for examination and testing, setting back eletrical or mechanical function and repair as necessary.
5. To prevent the risk of electrical shock, do not put / dip power cord or plug in water or other liquids.

6. Always clean the microwave oven after completion of use and do not immerse in water.
7. The use of equipment / tools not recommended and supplied by the manufacturer may cause fire, can be raises a risk of electric shock / short circuit and damage to the furnace microwave (microwave oven) you.
8. Do not use the microwave oven in open space.
9. Do not let the power cord hanging or nestled away on a side table or touch hot surfaces, including stove and etc.

Measures to avoid the possibility of excessive exposure of the microwaves

- Do not attempt to operate this oven with the door open, as long as the door is open, the process can result in harmful exposure to microwave energy. It is important not to impede or tamper with the safety interlocks section.
- Do not place any object between the oven front and the door or allow dust or residual cleanser accumulate on sealing surfaces / seals.
- Do not operate the oven if it is damaged. It is very important that the oven door closes properly and that there is no damage to the (1) door (bent), (2) hinges and latches (broken or loosened),
- (3) door seals and sealing surfaces. The oven must be adjusted or repaired by qualified service personnel.

Part 8: Specification

MODEL	MV 3116	MV 3133
Type	Microwave Convection Grill	Microwave Convection Grill
Installation Method	Freestanding / Built In	Freestanding / Built In
Oven Capacity (liter)	31	31
Number of Power Levels	10	10
Grill Function	Yes	Yes
Convection Function	Yes	Yes
Cabinet color	Stainless (S)	Stainless (S)
Cavity color	Stainless (S)	Stainless (S)
Color door cover	Black + Stainless	Black + Stainless
Timer	Yes	Yes
Control	Soft Touch	Soft Touch
Spinning plate	Yes	Yes
Oven lamp	Yes	Yes
Child lock	Yes	Yes
Program Defrosting	Yes	Yes
Power output microwave	900 W	900 W
Power output grill	1200 W	1200 W
Power output convection	1350 W	1350 W
Power Consumption	230V~50Hz,1450W	230V~50Hz,1450W
Outside Dimensions (WxDxH) mm	520 x 530 x 300	520 x 530 x 300
Oven Cavity Dimensions (WxDxH) mm	350 x 372 x 233	350 x 372 x 233
Weight (kg)	20	20

